



*Great sound  
from Barcelona  
since 1972*

[www.amateaudio.com](http://www.amateaudio.com)

## User's manual

# S15P

# NÍTiD

*#purelynitid*

April 2024

Amate Audio S.L.

EXPORT & CUSTOMER SERVICE  
Perpinyà, 25 · Polígon Industrial Nord  
08226 Terrassa · Barcelona – SPAIN  
T. +34 93 735 65 65  
[export@amateaudio.com](mailto:export@amateaudio.com)

R&D, FACTORY AND MANAGEMENT  
Violinista Vellsolà, 18  
08222 Terrassa · Barcelona – SPAIN  
T. +34 93 736 23 90  
[info@amateaudio.com](mailto:info@amateaudio.com)

## Safety Instructions

1. All safety instructions must be read before using this device.
2. Keep and follow these instructions
3. Heed all warnings
4. The exclamation mark in the triangle indicates internal components which if replaced can affect safety.
5. The lightning symbol within the triangle indicates the presence of dangerous uninsulated voltages.
6. Only clean the device with a dry cloth.
7. Do not block any ventilation openings. Install in accordance with the manufacturer's instructions.
8. Do not install the device near heat sources such as radiators, heaters or other heat-emitting elements.
9. Protect the power cord from being walked on or pinched, particularly at plugs, convenience receptacles, and the point where they exit from the apparatus
10. The equipment must be repaired by qualified technical service personnel when:
  - A. The mains supply cable is damaged, or
  - B. Any object or liquid has damaged the device; or
  - C. The equipment does not function normally or correctly; or
  - D. The equipment has been exposed to the rain; or
  - E. The chassis is damaged
11. Disconnect the device in the case of electric storms or during long periods of disuse.
12. **WARNING** – To reduce the risk of fire or electric shock, do not expose this device to rain or moisture
13. The equipment shall not be exposed to dripping or splashing and no objects filled with liquids, such as vases, shall be placed on the device.
14. For hanging and installation, use manufacturer recommended accessories only.

## 1. INTRODUCTION

### 1.1. General

Amate Audio would like to thank you for your confidence in our NÍTID Series. We suggest you to carefully read the following instructions in order to obtain the best results in performance.

### 1.2. Features and presentation

#### S15P

- Passive acoustic system
- NL4MP Speakon input & parallel output
- 800 W program power
- Sensitivity 1 W / 1 m: 99 dB
- 15" woofer with 3" voice coil
- 1.4" polyester diaphragm driver
- 50° to 100° (H) x 55° (V) asymmetrical dispersion horn
- Nominal impedance 8Ω

## 2. CONNECTIONS

### 2.1. Connection description

**A) SPEAKON:** The S15P uses two NL4MP Speakon terminals and are duly prepared for a perfect connection in a parallel system. Terminal Pins +1/-1 must be always used, disregarding the +2/-2 which are not internally connected. Respect always the polarity +/-.

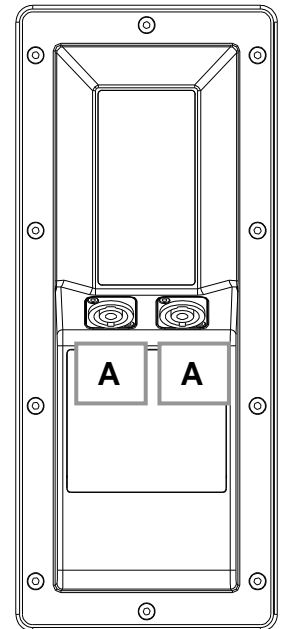

Fig. 1. NÍTID passive connectors



It is strongly recommended to use a two-conductor high quality wire, non-shielded and two-coloured. We recommend using a minimum section of 4 mm<sup>2</sup> for each conductor. Avoid long wire distances as they induce to important power and quality losses.

### 2.2. Configurations

#### 2.2.1. Full-range stereo configuration

Connect each output of the amplifier LEFT/RIGHT to each cabinet using two independent wires.

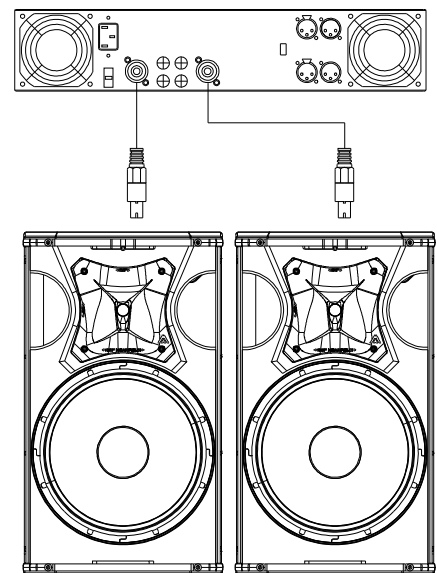
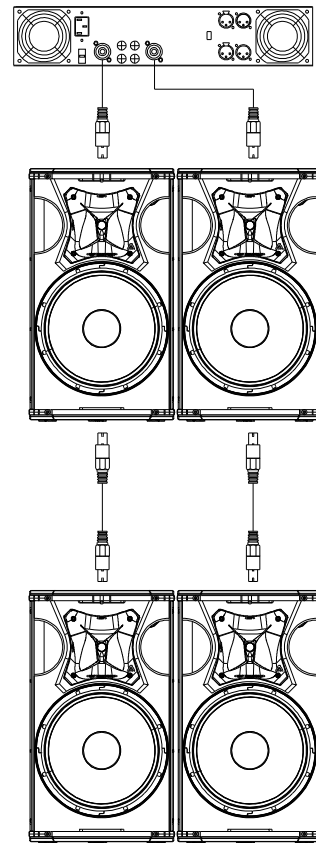

Fig. 2. Full-range stereo configuration

**2.2.2. Full-Range parallel stereo configuration**

Connect the amplifier's output to the Speakon's input of the first cabinet, always respecting the polarity positive +1, negative -1. Then, make a bridge from the first cabinet to the second one.



**Fig. 3.** Full-range parallel stereo configuration

**2.2.3. Passive configuration with subwoofer**

There will be times when you will be interested in reinforcing your NITID Systems with subwoofer units, in passive mode. In this case only one amplifier will be used for the whole system.

Connect one of the outputs of the amplifier to the subwoofer through a wire. Then, make a bridge from the link Speakon connector of the subwoofer to its respective mid-high top unit, always respecting the correct polarity between both systems. Do the same with the other channel.

It is also correct, if the installation requires so, to make the connection in the opposite way, that is, from the amplifier to the top cabinet and then to the subwoofer.

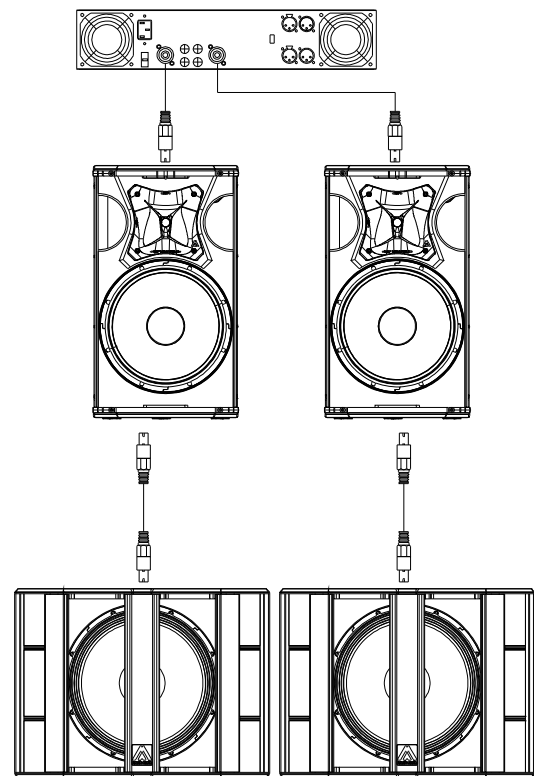

**Fig. 4.** Passive configuration with subwoofer

**2.2.4. Bi-Amplified configuration with subwoofer**

A wire with the maximum available section (4mm<sup>2</sup> minimum) should link the low frequencies output channel of the amplifier to one of the subwoofers. Two subwoofers can be also connected by bridge one to another, as long as the polarity is strictly respected.

Connect the other output of the amplifier to the Full-Range cabinets.

It is also possible to use only one amplifier for the low reinforcement, connecting each one of the subwoofers to the two outputs of the amplifier and consequently, connecting the Full Range cabinets to a second amplifier.

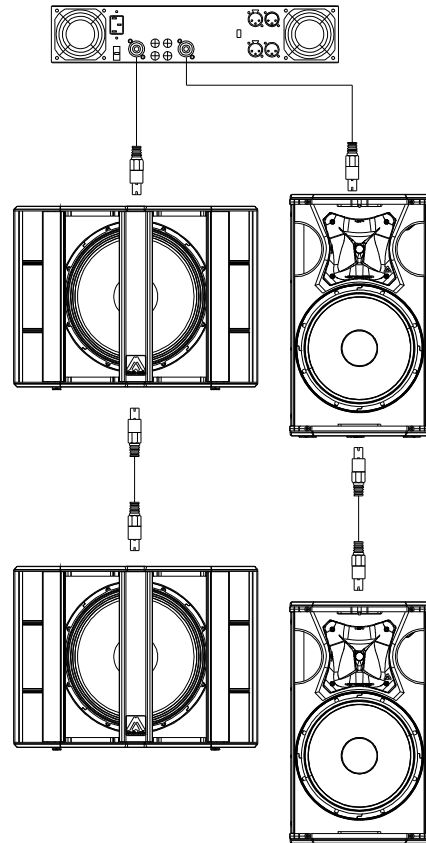

**Fig. 5.** Bi-amplified with subwoofer configuration (option 1)

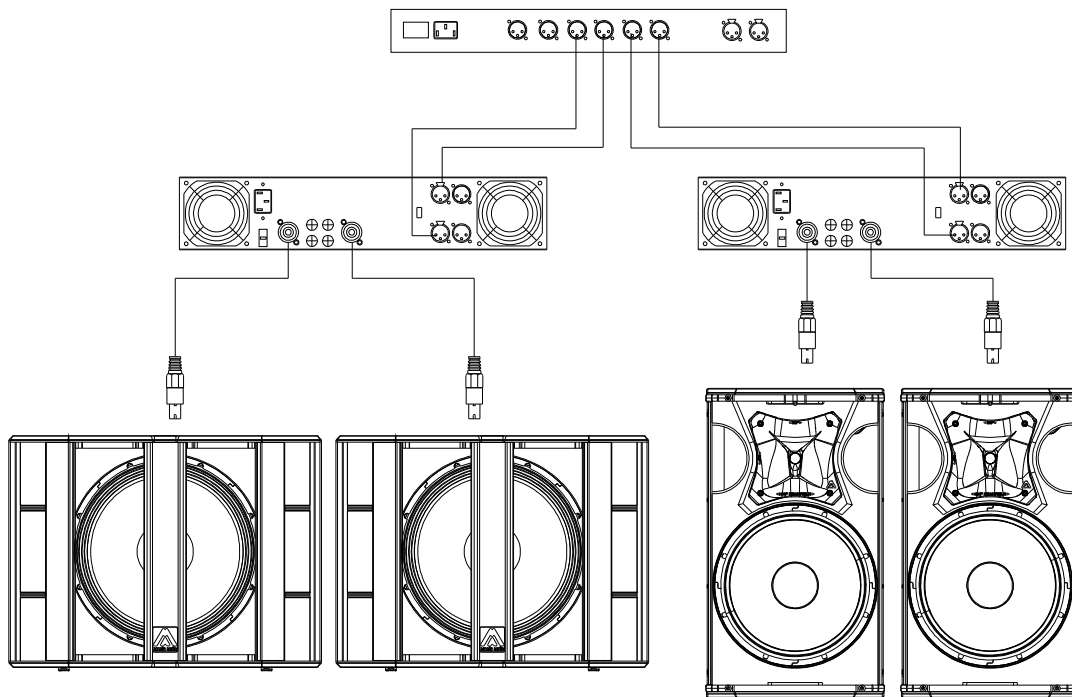

**Fig. 6.** Bi-amplified with subwoofer configuration (option 2)



In order to allow a bridge connection between cabinets, each one of them has been provided with two Speakon connectors that allow the Input / Output function indistinctly. Terminal Pins +1/-1 must be always used, disregarding the +2/-2 which are not internally connected.

### 3. MOUNTING AND PLACEMENT

Flying an S15P system is easy, fast and secure. To perform any operations related to flying the system, read the present document, and act on the warnings and advice given.

Only experienced installers with adequate knowledge of the system and local safety regulations should fly speaker cabinets.

It is the user's responsibility to ensure that the systems to be flown and the flying accessories (such as chains, eyebolts, lock pins...) comply with state and local regulations. They should be regularly inspected and replaced if in doubt.

When flying enclosures from ceiling support structures, extreme care should be taken to assure the load bearing capabilities of the structures. **Do not fly systems from unsafe structures.**

All flying accessories that are not supplied by Amate Audio are the user's responsibility. Use at your own risk. **Remember that no risks should be taken with regards to public safety.**

#### 3.1. Placement

When possible, cabinets should be located in a high position, slightly inclined to the audience. If the loudspeakers are located too low, the listeners at the end of the room will not hear a good sound quality.

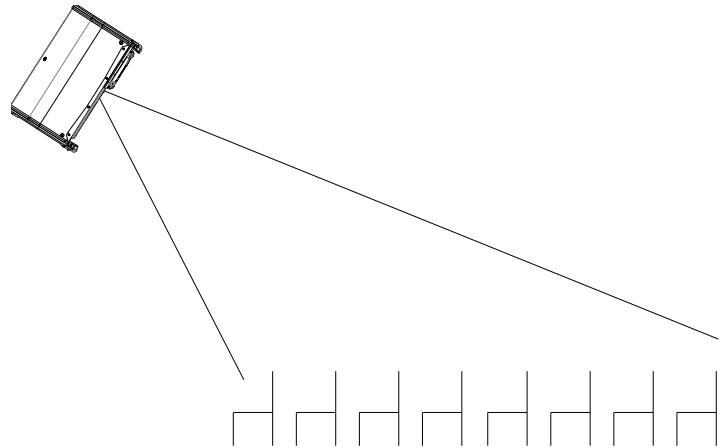

**Fig. 7.** Flying placement

#### 3.2. S15P with subwoofer

The S12P is equipped with a 35 mm socket for mounting the speaker on a subwoofer (use SP/CRTL bar) or on a tripod. Be careful not to use this system on non-flat surfaces as it may become unstable.

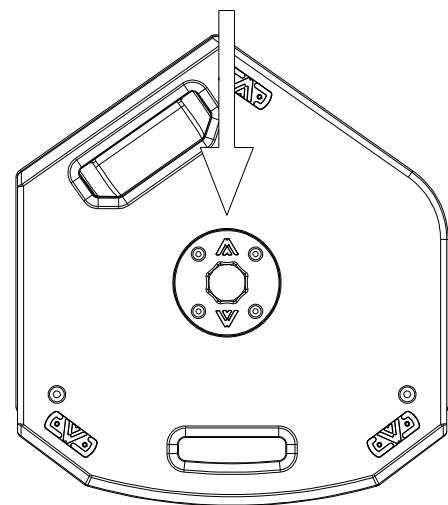

**Fig. 8.** S15P 35 mm bottom socket

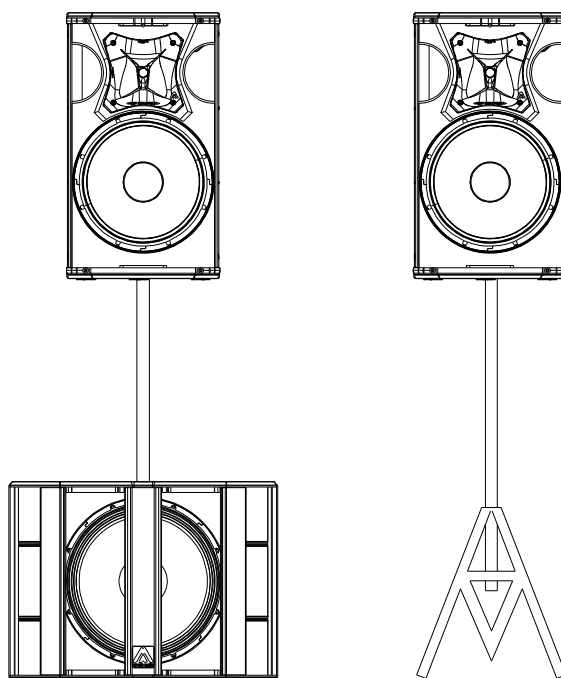

**Fig. 9.** Use with subwoofer or tripod

### 3.3. Asymmetrical and rotatable horn

The S15P incorporates an asymmetrical dispersion horn, which will optimise coverage.

To rotate the horn, unscrew the frontal grille, and then, unscrew the four fixing screws of the horn. Rotate it 180 degrees taking care of the wires. Screw the horn again and finally place the frontal grille in its right position.

Good coverage of audiences often is a conflicting combination of:

- wide coverage for the closest audience (short throw)
- narrow coverage for distant areas (long throw)

The asymmetrical dispersion horn coverage varies from "short throw" to "long throw" along the vertical axis (keeping a constant vertical directivity). In conclusion, directivity feature of (50° to 100°(H), 55°(V)) can be seen as if the horn itself had "two" horizontal directivities, which depend on the distance. For short distances, the horn should be used with its "wide" dispersion (100°). For long distances, the horn should be used with its "narrow" dispersion (50°). We suggest you to pay attention to the following examples.

#### 3.3.1. Vertical-Positioned Cabinets (Flown and aiming to the audience)

We need wide coverage (100°) for the closest listeners and narrow coverage for the distant audience.

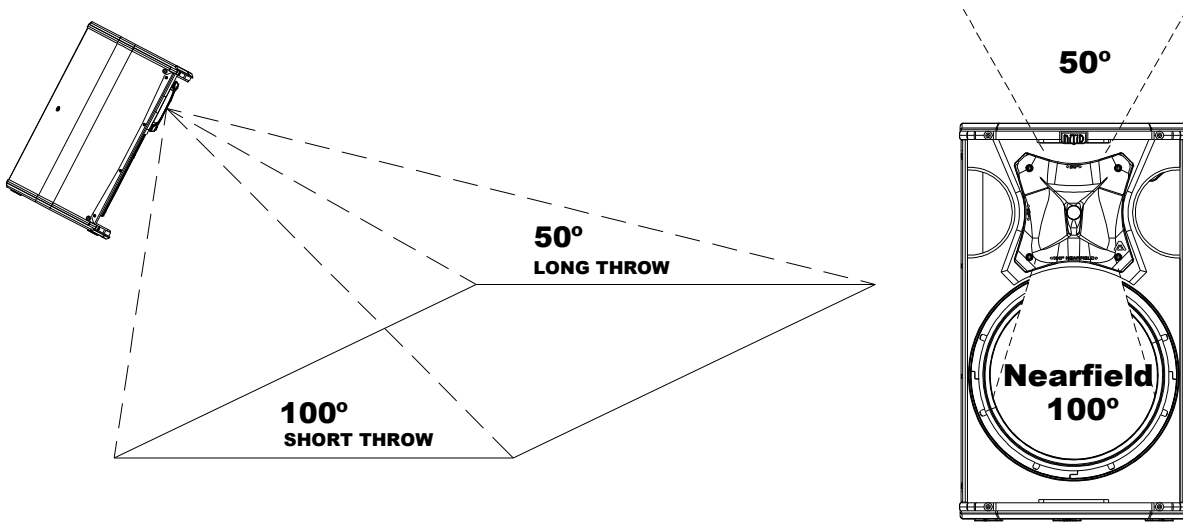

Fig. 10. Vertical position

### 3.3.2. Horizontal-Positioned Cabinets (Flown and aiming to the audience)

We need wide coverage (100°) for the closest listeners and narrow coverage for the distant audience.

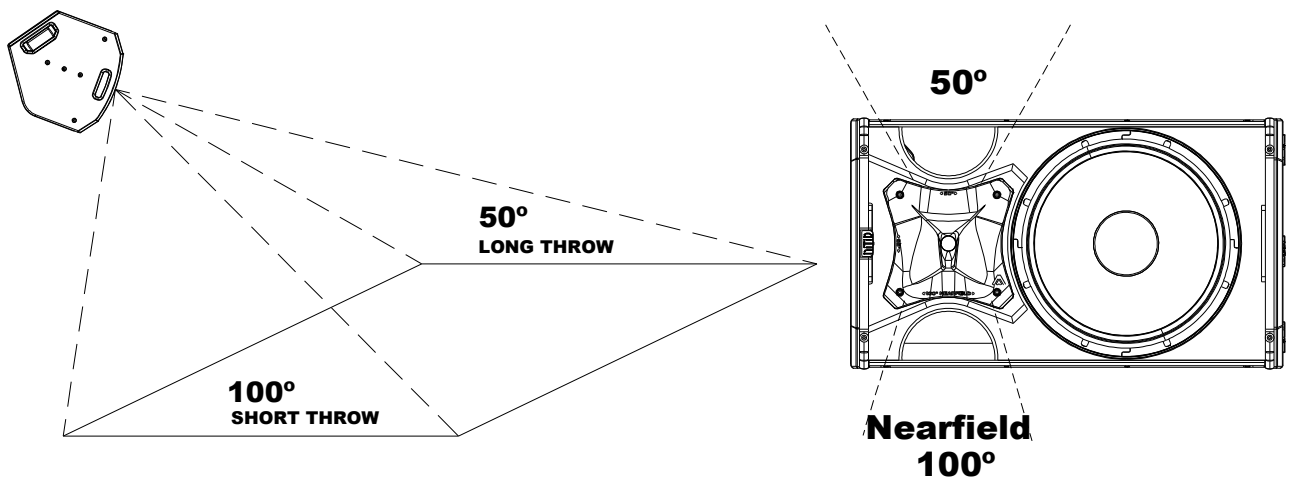
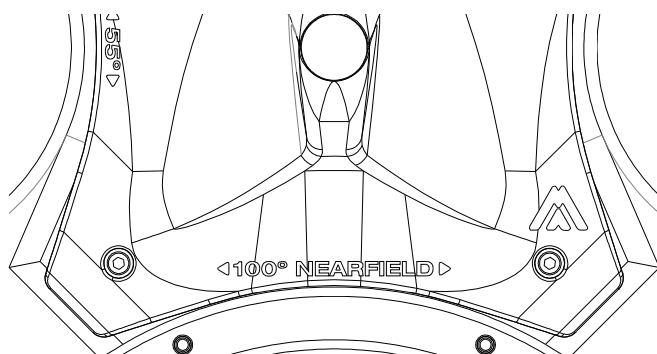

Fig. 11. Horizontal position



 The horns have the "Nearfield" mark printed on the 100° horizontal coverage side.

Fig. 12. "Near Field" logo



### 3.3.3. Stage monitor use

#### Case 1

We need wider coverage ( $100^\circ$ ) when musicians are closer to the cabinet than when they move away from it ( $50^\circ$ ).

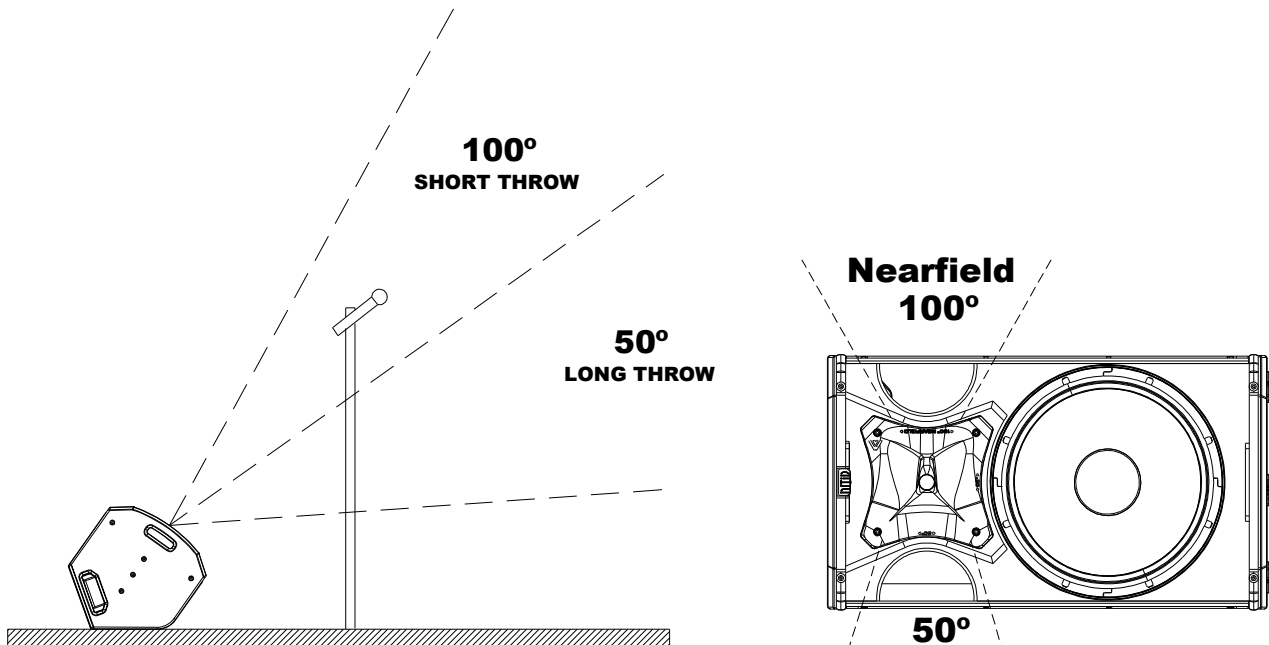

**Fig. 13.** Stage monitor use (case 1)

#### Case 2

We need wider coverage ( $100^\circ$ ) when performers move away from the cabinet (long stages) than when they are close to it ( $50^\circ$ ).

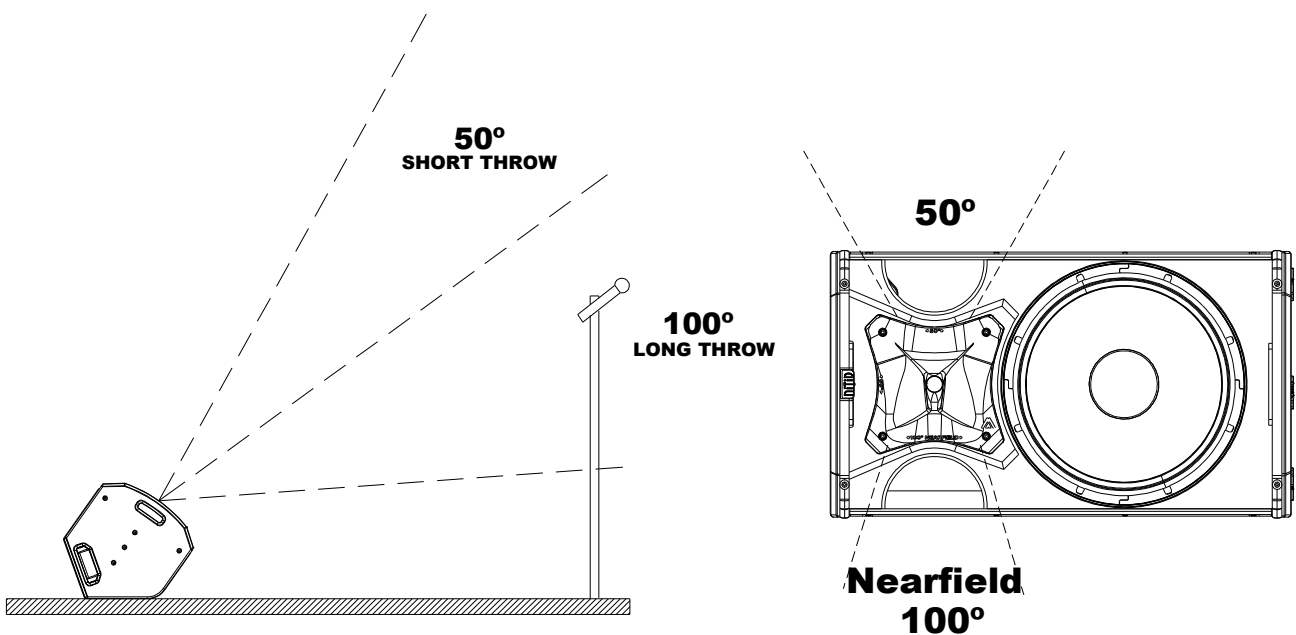

**Fig. 14.** Stage monitor use (case 2)

### 3.4. Rotatable logo

All grille's logo can be rotated.

### 3.5. Stage monitor use

The wedge shape of S15P allows for use as onstage monitor without the need of incorporating any other accessory. Remember to use the MONITOR preset on your external processor.

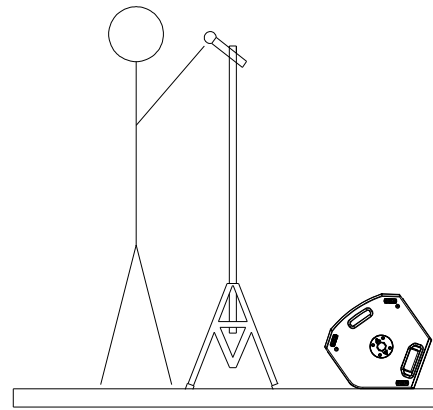

**Fig. 15.** Use as on-stage monitor

### 3.6. Flying

Only experienced people should fly speaker cabinets. Extreme care should be taken to assure the load bearing capabilities of the structures where the cabinets will be placed. Hanging hardware (as chains, eyebolts, lock pins...) should be regularly inspected and replaced if in doubt.



**DO NOT SUSPEND THE CABINETS FROM THE HANDLES**

#### 3.6.1. Vertical flying with HR-LU and HR-LU/GT bar

The HR-LU and the HR-LU/GT are some optional accessories for flying on truss or ceiling (vertical orientation) one unit of S15P. Refer to “HR-LU instructions manual” and “HR-LU/GT instructions manual” for more information.

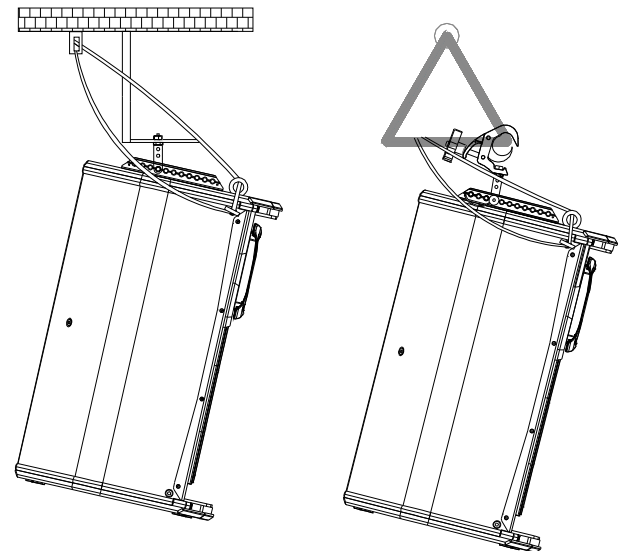

**Fig. 16.** HR-LU and HR-LU/GT flying bar for S15P

#### 3.6.2. Vertical flying with SP-WHR

The SP-WHR is an optional accessory for mounting on wall (vertical orientation) one unit of S15P. Refer to “SP-WHR instructions manual” for more information.

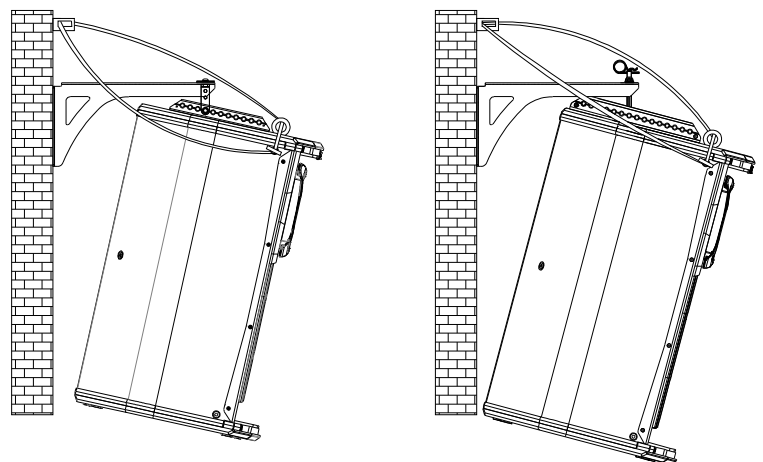
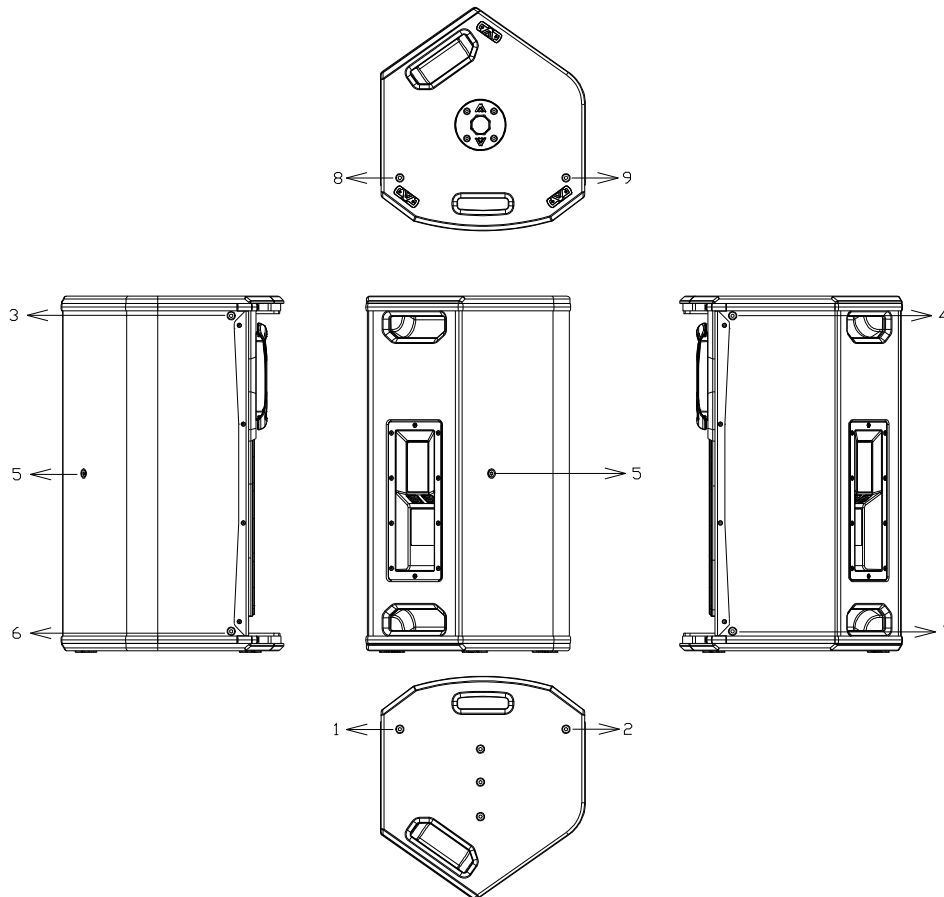

**Fig. 17.** SP-WHR bracket for S15P

### 3.6.3. Flying with ACRM8

The S15P provides several M8 flying points. Their correct use will permit the flying in vertical position or horizontal position.

<b>S15P</b>	
<b>Horizontal flying</b>	3&6 or 4&7 or 1&8 or 2&9 (front rigging points) 5 (back tilt point)
<b>Vertical Flying</b>	1&2 or 3&4 (front rigging points) 5 (back tilt point)



**Fig. 18.** S15P rigging points

### 3.6.4. Horizontal flying with UB-L

The UB-L is an optional accessory for mounting on wall (horizontal orientation) one unit of S15P. Refer to “UB-L instructions manual” for more information.

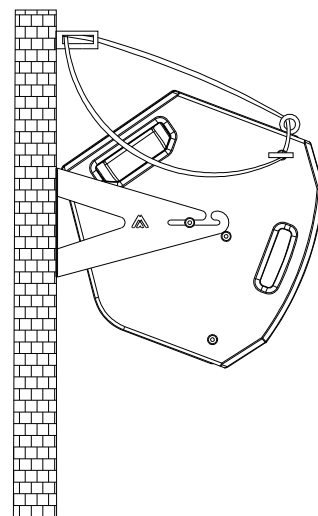

**Fig. 19.** U-BL bracket for S15P

### 3.6.5. Vertical flying with RB-L and RB-L/GT bar

The RB-L and the RB-L/GT are some optional accessories for flying on truss or ceiling (vertical orientation) one unit of S15P. Refer to “RB-L instructions manual” and “RB-L/GT instructions manual” for more information.

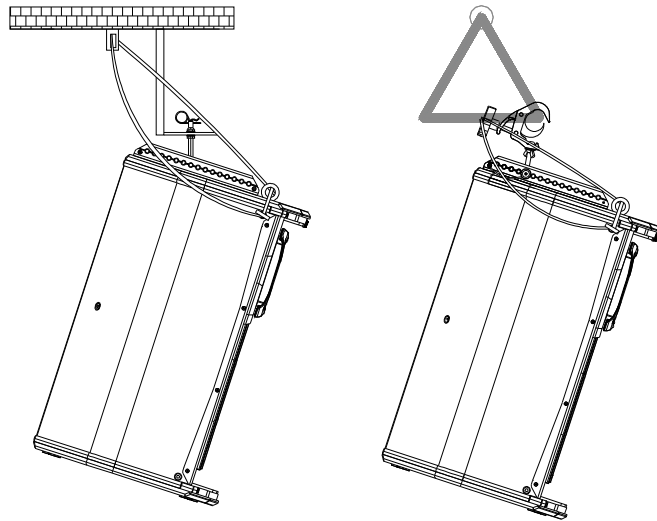

**Fig. 20.** RB-L and RB-L/GT flying bar for S15P

## 4. TECHNICAL FEATURES

	<b>S15P</b>
<b>Impedance</b>	
Nominal	8 Ω
<b>Power</b>	
R.m.s	400 W
Program	800 W
Connectors	1 x Speakon NL4MP input 1 x Speakon NL4MP link
<b>Audio Performance</b>	
Frequency response (-10 dB usable bandwidth)	50 Hz – 19k Hz
SPL (1W / 1m)	99 dB
Nominal directivity (-6dB)	50° to 100° x 55°
<b>Components</b>	
LF	15" woofer (3" voice coil)
HF	1 x 1.4" polyester diaphragm driver
<b>Cabinet</b>	
Type	Bass-reflex
Height	733 mm
Width	423 mm
Depth	460 mm
Weight (net)	24.8 Kg
Material	Multilayer birch plywood
Finish	Hi-resistance black matt Polyurea coating and protective rubber profiles . 1.5 mm steel front grille with black acoustic mesh

**Note:** Specifications subjected to change without prior notice.



*Great sound  
from Barcelona  
since 1972*

---

The **NÍTID** loudspeaker systems have been designed,  
engineered and manufactured in Barcelona – SPAIN  
by

---

**Amate Audio S.L.**

Perpinyà, 25 · Polígon Industrial Nord · 08226 Terrassa  
T. +34 93 735 65 65 – F. +34 93 735 60 48 –  
info@amateaudio.com

R&D and FACTORY:  
Violinista Vellsolà, 18 · 08222 Terrassa  
T. +34 93 736 23 90 – F. +34 93 786 47 00

**Barcelona – SPAIN**

---

[www.amateaudio.com](http://www.amateaudio.com)