



*Great sound
from Barcelona
since 1972*

www.amateaudio.com

User's manual

N12A6

NÍTiD

#purelynitid

April 2024

Amate Audio S.L.

EXPORT & CUSTOMER SERVICE
Perpinyà, 25 · Polígon Industrial Nord
08226 Terrassa · Barcelona – SPAIN
T. +34 93 735 65 65
export@amateaudio.com

R&D, FACTORY AND MANAGEMENT
Violinista Vellsolà, 18
08222 Terrassa · Barcelona – SPAIN
T. +34 93 736 23 90
info@amateaudio.com

Safety Instructions

- 1.** All safety instructions must be read before using this device.
- 2.** Keep and follow these instructions
- 3.** Heed all warnings
- 4.** The exclamation mark in the triangle indicates internal components which if replaced can affect safety.
- 5.** The lightning symbol within the triangle indicates the presence of dangerous uninsulated voltages.
- 6.** Only clean the device with a dry cloth.
- 7.** Do not block any ventilation openings. Install in accordance with the manufacturer's instructions.
- 8.** Do not install the device near heat sources such as radiators, heaters or other heat-emitting elements.
- 9.** Protect the power cord from being walked on or pinched, particularly at plugs, convenience receptacles, and the point where they exit from the apparatus
- 10.** The equipment must be repaired by qualified technical service personnel when:
 - A.** The mains supply cable is damaged, or
 - B.** Any object or liquid has damaged the device; or
 - C.** The equipment does not function normally or correctly; or
 - D.** The equipment has been exposed to the rain; or
 - E.** The chassis is damaged
- 11.** Disconnect the device in the case of electric storms or during long periods of disuse.
- 12.** **WARNING** – To reduce the risk of fire or electric shock, do not expose this device to rain or moisture
- 13.** The equipment shall not be exposed to dripping or splashing and no objects filled with liquids, such as vases, shall be placed on the device.
- 14.** For hanging and installation, use manufacturer recommended accessories only.

1. INTRODUCTION

1.1. General

Amate Audio would like to thank you for your confidence in our NÍTID Series. We suggest you to carefully read the following instructions in order to obtain the best results in performance.

1.2. Features and presentation

N12A6

- Self-powered acoustic system
- XLR electronically balanced input & XLR parallel output
- AC PowerCon input and link
- 500 W Class-D amplifier for low-mid range
- 100 W Class-D amplifier for high range
- 24-bit AD/DA converters, 48 kHz sampling rate
- Self amplifier diagnostics: output power, temperature, clipping
- DSP Controls (delay, volume, PEQ, presets and limiter)
- 1 x 12" woofer with 2.5" voice coil
- 1.4" PETP diaphragm magnet compression driver
- 50° to 100° (H) x 55° (V) asymmetrical dispersion horn

1.3. N12A6 presets

The N12A6 includes several manufacturer presets for different types of applications.

PRESET 1: Flat

Single enclosure without subwoofer, full range, flat response. For pole mount or hanged applications.



PRESET 2: Speech

Single enclosure without subwoofer, full range, flat response. For speakers using microphone.

-3dB low
-3dB high



PRESET 3: Monitor

Single enclosure without subwoofer full range, flat response. For stage monitor applications.

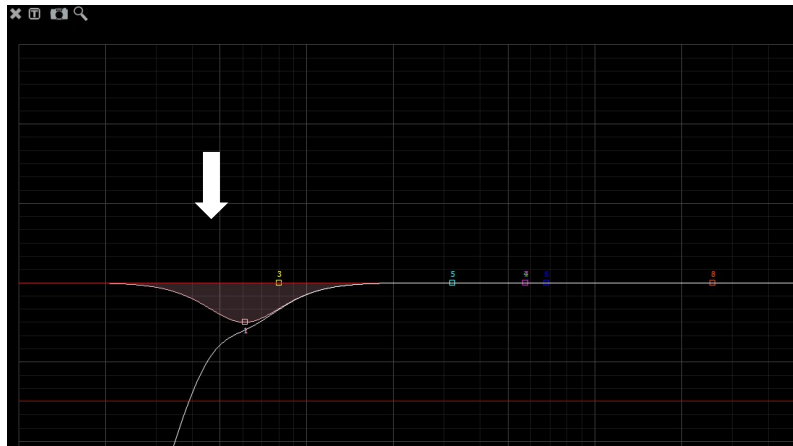
**PRESET 4: HPF90**

For using with subwoofer. HPF at 90 Hz.



Fig. 1. Presets for N12A6

2. CONNECTIONS

2.1. Connection Panel

The power and audio connections are located on the unique panel, shown in 2. The different parts of the panel are explained in detail in the following sections of the manual.

Control:

A) LCD: Displays information about the system status. The main screen shows the following information.

- Current preset
- Input Level
- Output Level LF Channel
- Output Level HF Channel
- Amplifier temperature
- ECO mode enabled/disabled
- Keypad locked/unlocked

B) KEYPAD: Allows the user to perform basic operations on the DSP such as Preset selection, audio settings and user preferences. There are three keys available:

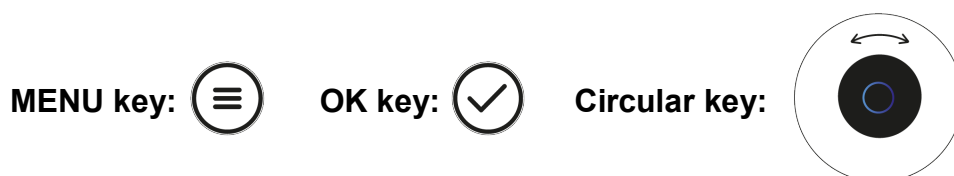

To enter the menu the keypad must be unlocked by pressing simultaneously the MENU and OK keys.

The central circle of the circular key will light up in blue when this key is active.

C) PROTECTION LED: This led lights up when the amplifier is in a protection situation (such as temperature excess, overcurrent, or other situations that can compromise the amplifier's integrity). It will also light up when the amplifier is in standby mode. This happens for a couple of seconds at start-up.

The Protection led will light off when the amplifier recovers from the abnormal situation. Shall the Protection led keep up lighted on even after a system restart, please contact an authorized service.

D) LIMITER ON LED: The limiter led lights up to indicate that the amplifier is delivering the maximum power set by the limiter circuit. The limiter prevents the loudspeaker from receiving excessive or distorted signal. Continuous lighting of this led indicates that the signal is being massively compressed. In this case, the input level should be reduced in order to get a proper dynamic headroom.

Model Specifications:

E) MODEL DATA: The basic data of the model is found here:

- Model reference
- Amplifier program power (Watts)
- Maximum Sound Pressure Level Continuous delivered by the system (dB SPL)

F) AUTHENTICATION QR CODE: This QR code is a smart label that ensures that the product is an original Amate Audio product. To verify the authenticity, please follow the instructions in the following link:

<http://www.amateaudio.com/en/product-authentication/>

Connections:

G) AC MAINS INPUT: Mains supply connection via PowerCon. Use the blue connector for AC input.



Always use mains power cable supplied by manufacturer.

Never connect the NITID cabinets to an unearthed mains supply or by using an unearthed mains cable.

H) AC LINK: Grey connector to feed other units in parallel. Linking up to 20 units is possible, provided that a quality cable of a minimum section of 3 x 2.5 mm² is used. Connecting more than 20 units in parallel may lead to a voltage drop in the cable that will reduce the equipment performance.



Fig. 2. N12A6 control and connection panel

I) BALANCED INPUT/LINK:

XLR-3 Female balanced signal connector for signal input and XLR-3 Male connector for parallel connection of various cabinets with the same input signal.



Please always use balanced microphone cable with the following pin assignment: 1 Shield / 2 (+) Live / 3 (-) Return

2.2. Configurations

2.2.1. Parallel connection

Connect the signal (mixing desk output) to INPUT on the first unit. Use the LINK output to transfer the INPUT signal to the second unit and thus sequentially for further units. All of the units in this chain must be switched on.

For the mains connection use the cable with the blue PowerCon.

You can use the mains connection in parallel by using a cable with grey PowerCon at one end and the blue PowerCon at the other end.

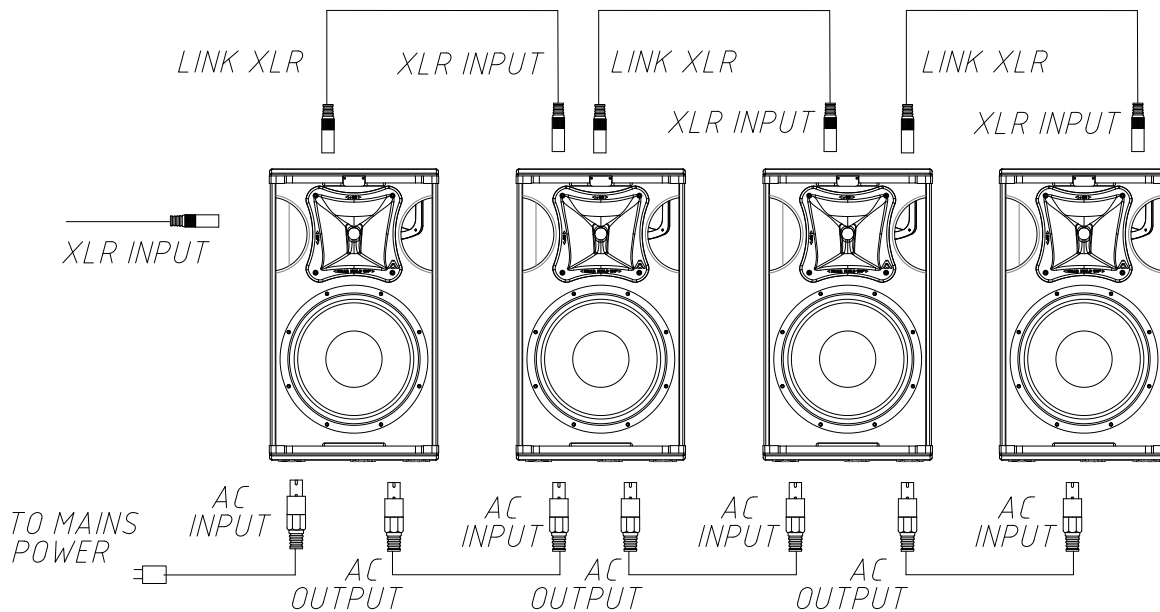

Fig. 3. Parallel connection for N12A6 cabinets (signal and mains)



Do not connect NÍTID series units using PowerCon without earth.
Do not connect more than 20 units using the AC output link connector.

2.2.2. Parallel connection with other equipment

You can connect other NÍTID loudspeakers or subwoofers in parallel with N12A6 cabinets. Please, follow the same parameters as explained in Fig. 3.

3. MOUNTING AND PLACEMENT

For a proper installation of the acoustic cabinet systems, it is strongly recommended to carefully read the following advices.

3.1. Placement

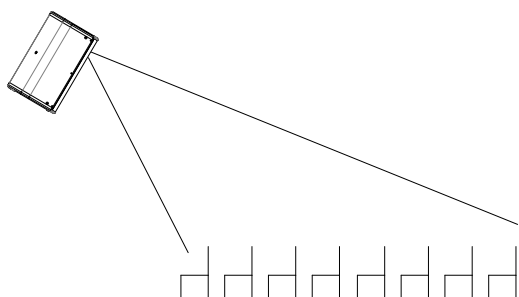

When possible, cabinets should be located in a high position, slightly inclined to the audience. If the loudspeakers are located too low, the listeners at the end of the room will not hear a good sound quality.

Fig. 4. Flying placement

3.2. N12A6 with subwoofer

The N12A6 is equipped with a 35 mm socket for mounting the speaker on a subwoofer. Be careful not to use this system on non-flat surfaces as it may become unstable.

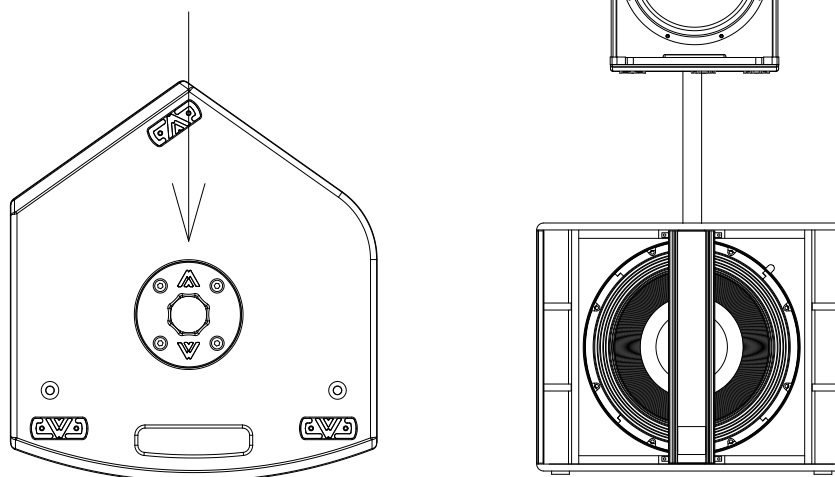

Fig. 5. N12A6 with subwoofer

3.3. Asymmetrical and rotatable horns

The N12A6 incorporates an asymmetrical dispersion horn which will optimise coverage.

To rotate the horn, unscrew the frontal grille, and then, unscrew the four fixing screws of the horn. Rotate it 180 degrees taking care of the wires. Screw the horn again and finally place the frontal grille in its right position.

Good coverage of audiences often is a conflicting combination of:

- wide coverage for the closest audience (short throw)
- narrow coverage for distant areas (long throw)

The asymmetrical dispersion horn coverage varies from "short throw" to "long throw" along the vertical axis (keeping a constant vertical directivity). In conclusion, directivity feature of (50° to 100°(H), 55°(V)) can be seen as if the horn itself had "two" horizontal directivities, which depend on the distance. For short distances the horn should be used with its "wide" dispersion (100°). For long distances the horn should be used with its "narrow" dispersion (50°). We suggest you to pay attention to the following examples.

3.3.1. Vertical-Positioned Cabinets (Flown and aiming to the audience)

We need wide coverage (100°) for the closest listeners and narrow coverage for the distant audience.

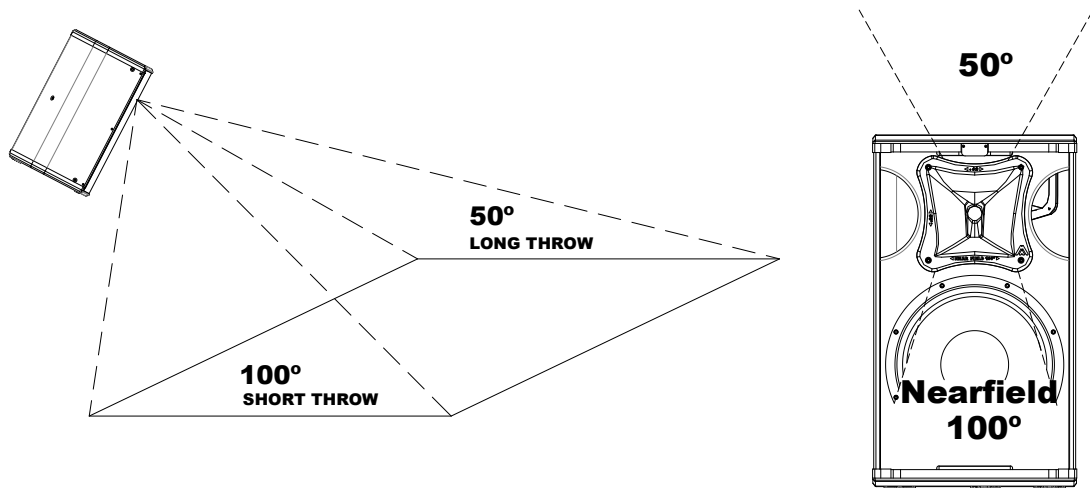

Fig. 6. Vertical position

3.3.2. Horizontal-Positioned Cabinets (Flown and aiming to the audience)

We need wide coverage (100°) for the closest listeners and narrow coverage for the distant audience.

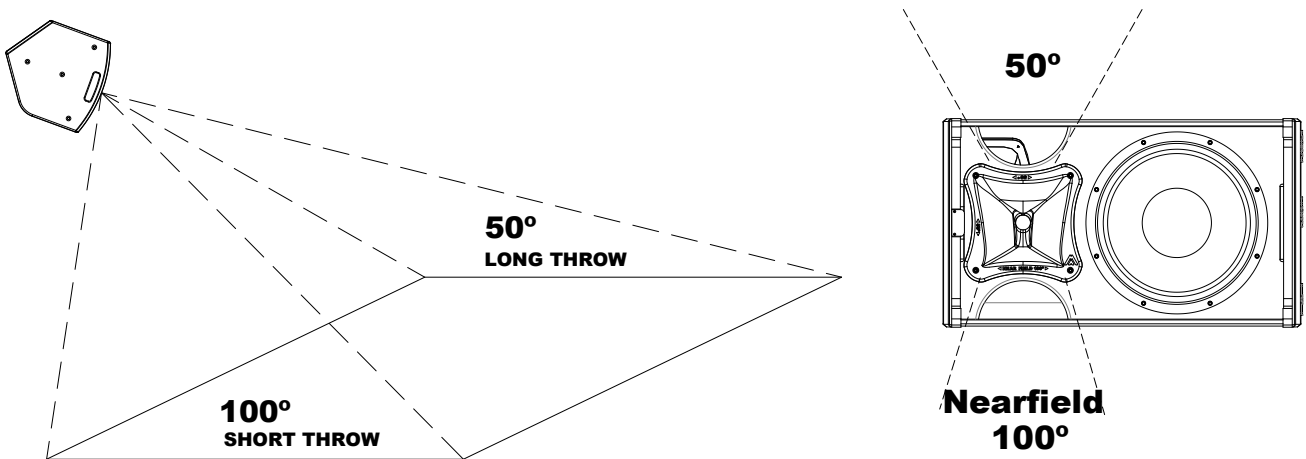

Fig. 7. Horizontal position



The horns have the "Nearfield" mark printed on the 100° horizontal coverage side.

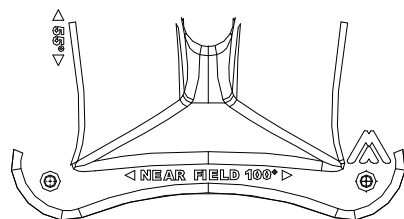

Fig. 8. "Near Field" logo

3.3.3. Stage monitor use

Case 1

We need wider coverage (100°) when musicians are closer to the cabinet than when they move away from it (50°).

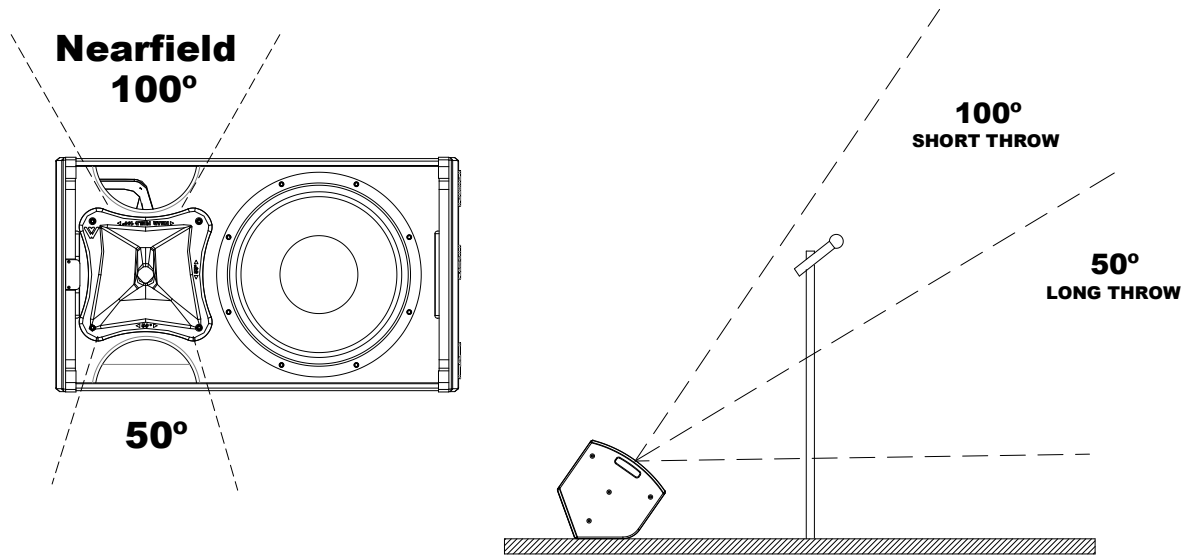

Fig. 9. Stage monitor use (case 1)

Case 2

We need wider coverage (100°) when performers move away from the cabinet (long stages) than when they are close to it (50°).

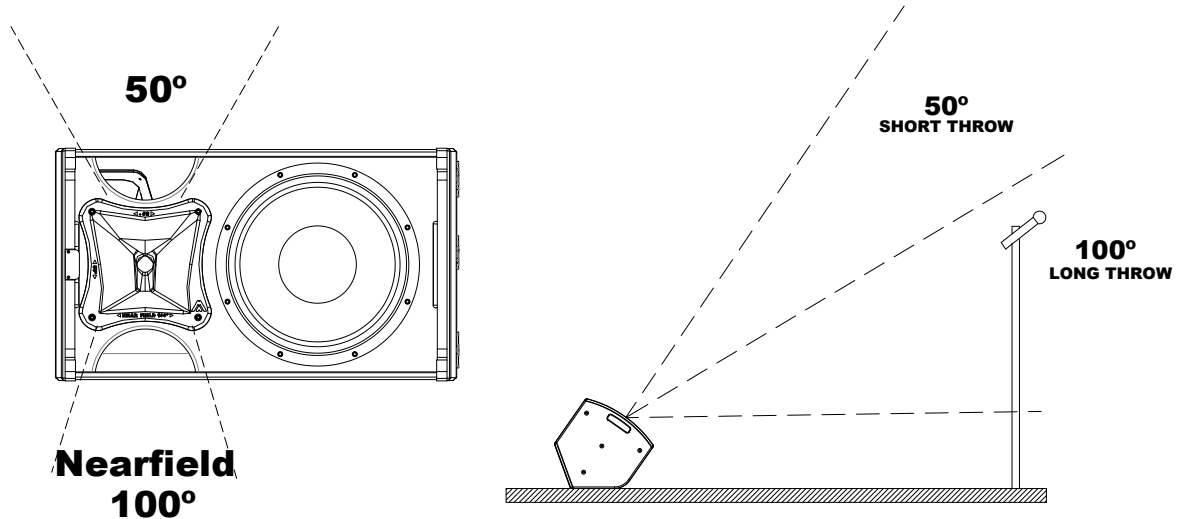

Fig. 10. Stage monitor use (case 2)

3.4. Rotatable logo

Grille's logo can be rotated.

3.5. Stage monitor use

The wedge shape of N12A6 allows for use as onstage monitor without the need of incorporating any other accessory. Remember to use the MONITOR preset in this case.

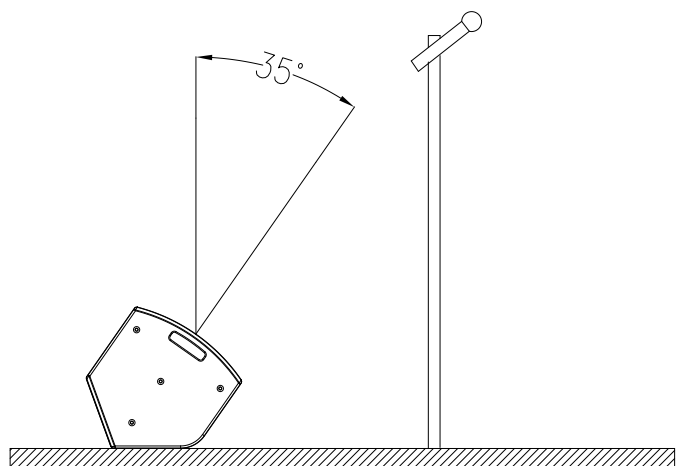

Fig. 11. Use as on-stage monitor

3.6. Flying

Only experienced people should fly speaker cabinets. Extreme care should be taken to assure the load bearing capabilities of the structures where the cabinets will be placed. Hanging hardware (as chains, eyebolts, lock pins...) should be regularly inspected and replaced if in doubt.



DO NOT SUSPEND THE CABINETS FROM THE HANDLES

3.6.1. Flying with ACR-M8 eyebolts

The N12A6 provides several M8 flying points. Their correct use will permit the flying in horizontal or vertical position.

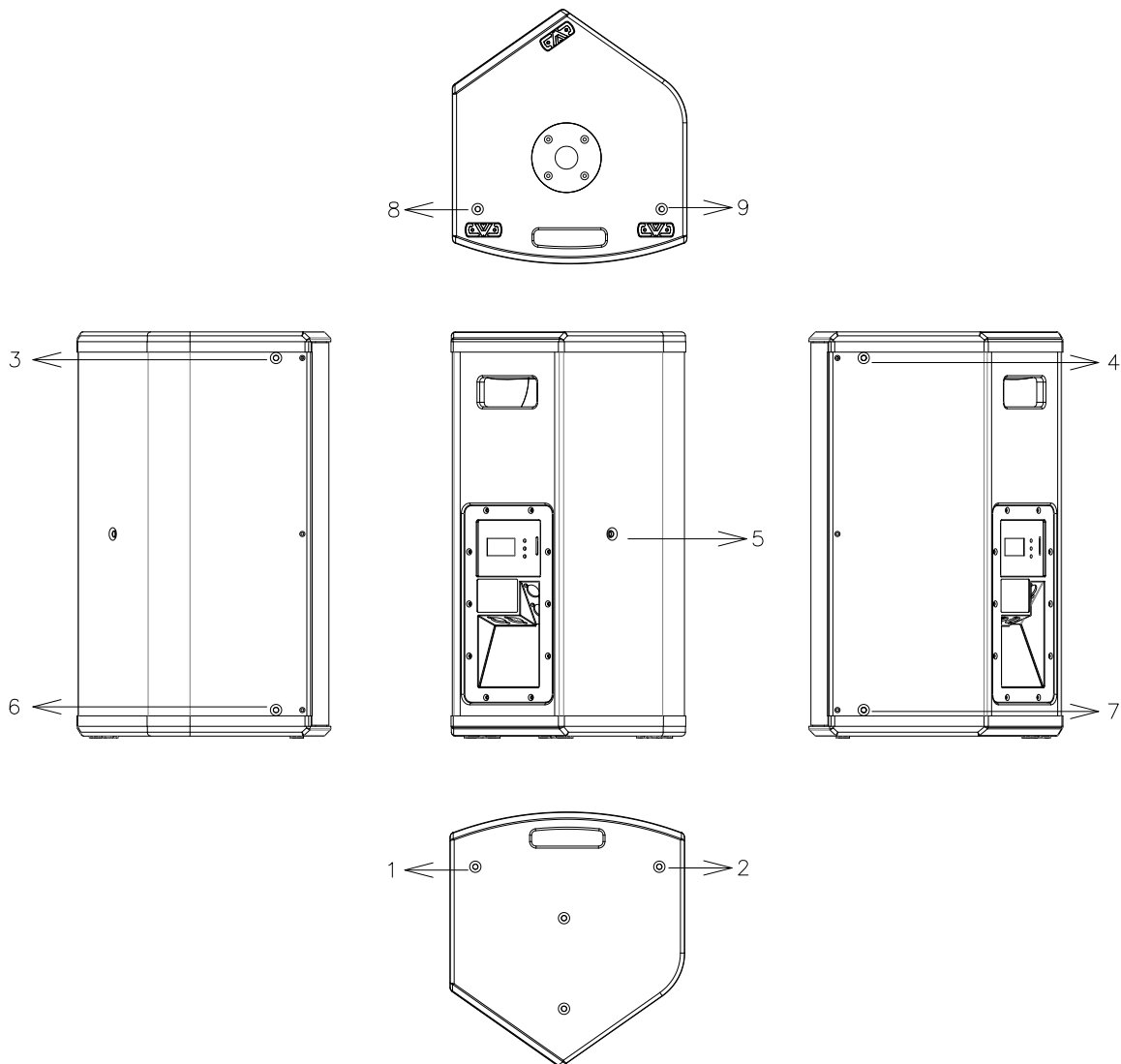

Fig. 12. N12A6 rigging points

	N12A6
Horizontal flying	3&6 or 4&7 or 1&8 or 2&9 (front rigging points) 5 (back tilt point)
Vertical Flying	1&2 or 3&4 (front rigging points) 5 (back tilt point)

3.6.2. Horizontal flying with “U-BL”

The UB-L is an optional accessory for wall mounting (horizontal orientation). Please, refer to “UB-L user’s manual” to get more information.

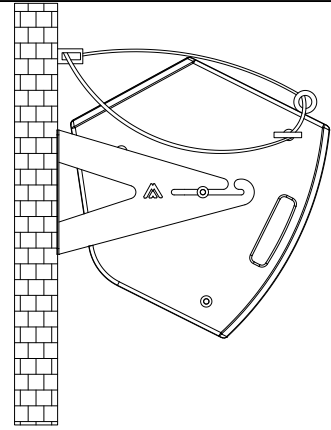

Fig. 13. Flying with U-BL

3.6.3. Vertical flying with HR-S bar

Use the HR-S or HR-S/GT flying bar for vertical flying. Refer to “HR-S instructions manual” and “HR-S/GT instructions manual” for more information.

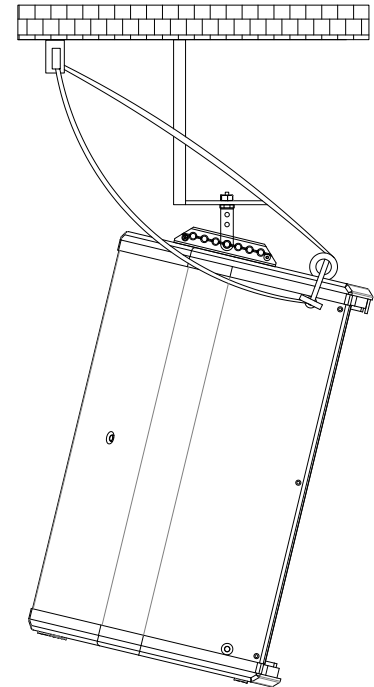

Fig. 14. HR-S flying bar

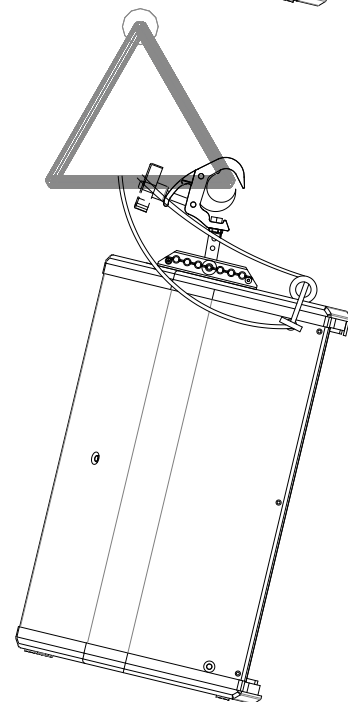

Fig. 15. HR-S/GT flying bar

3.6.4. Vertical flying with SP-WHR

The SP-WHR is an optional accessory for mounting on wall (vertical orientation) one unit N12A6. Refer to “SP-WHR instructions manual” for more information.

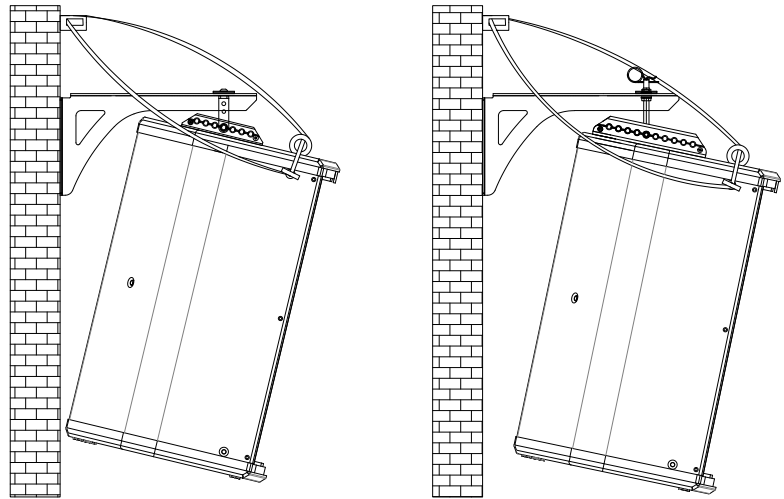

Fig. 16. SP-WHR bracket

3.6.5. Vertical flying with RB-S bar and RB-S/GT bar

Use the RB-S or RB-S/GT flying bar for vertical flying. Refer to “RB-S instructions manual” and “RB-S/GT instructions manual” for more information.

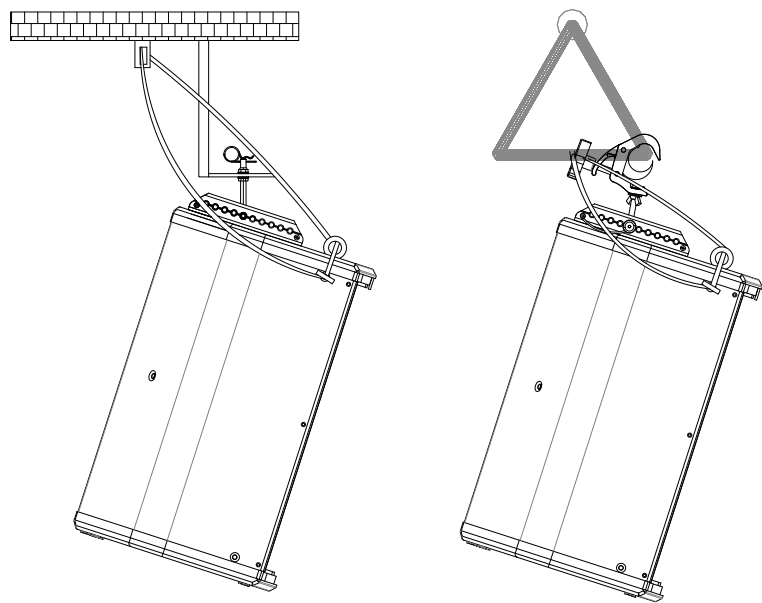

Fig. 17. RB-S and RB-S/GT flying bar

3.7. NITID GRILLE

To remove the front grille, first remove the screws on both the left and right side. Insert two bent paper clips into the holes in the grille and carefully pull it off.

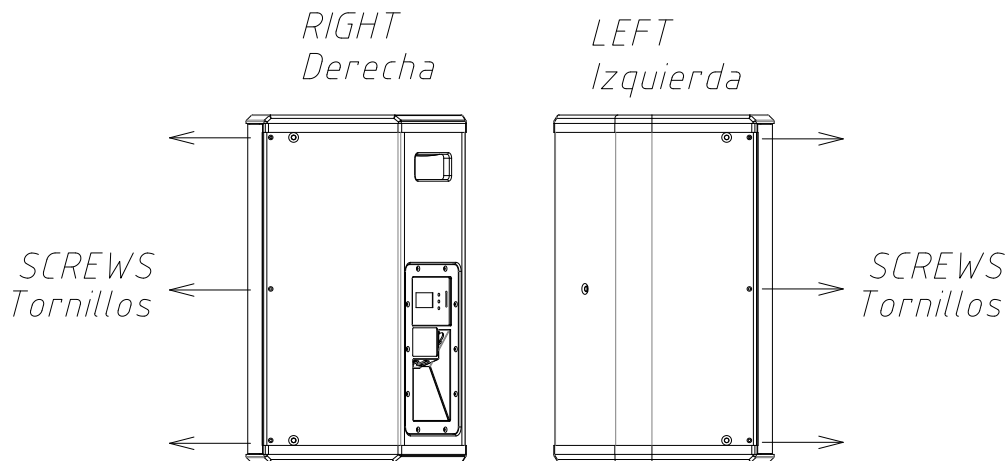
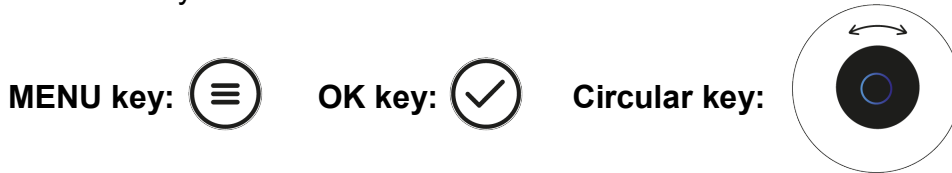





Fig. 18. Grille screws

4. DSP SYSTEM SETUP

Thanks to their internal microcontroller and DSP System, the NITID Active cabinets can be configured for different applications. This section explains all the possible configurations.

The LCD and keypad on the cabinet’s back panel are used for the setup. The available keys are:



 To enter the Menu, the keypad must be unlocked
 Press  and  simultaneously to unlock the Keypad

4.1. Start-up and Main Screen

At start-up the LCD screen will show the Amate Audio and NITID logo. After a few seconds, the main screen shown in Fig. 19 will be displayed:

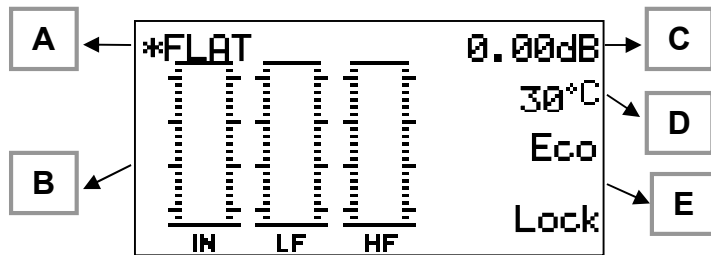



Fig. 19. Main screen display

The following information is displayed on the screen:

- A) Current preset. An asterisk (*) is shown when the preset has been modified using the Audio Settings menu.
- B) Input and Output levels
- C) Gain level
- D) Temperature of the power stage
- E) Special features
 - Eco: when ECO Mode is enabled
 - Lock: shows when the keypad is locked

 When the keypad is unlocked, you can use the circular key (sliding your finger along the white circle area) to directly access the Main Gain Control

4.2. Browsing the menus

To browse the menus, the MENU and OK keys are used. Always remember to unlock the keypad to perform an action.

Press the MENU key once to access the main menus. The first option displayed will be



Fig. 20. Presets option in Main Menu

“PRESETS”. Press MENU again to browse the different available menus, as following:

- PRESETS: To change the factory preset of the DSP
- AUDIO: To change different settings related to audio performance, such as Gain, PEQ, Limiter and Delay
- SETUP: To change the interface settings, such as the Eco Mode, front Led, etc.
- INFO: Displays all the system information. In this menu is possible to change the language and restore the settings to the factory default.
- BACK: Return to main screen

To enter one of the above listed sub-menus, press OK.



To return to the main screen from any menu screen, press MENU continuously for more than two seconds. Additionally, after 30 seconds of inactivity, the system will go automatically back to the main screen, saving all the values that have been changed.

4.3. PRESETS Menu

When the word PRESETS is displayed, press OK. The current preset will be displayed.

Press MENU to browse the available presets. Each time a Preset is displayed, it will be loaded to the DSP. When the desired Preset is on screen, press OK to leave the menu.

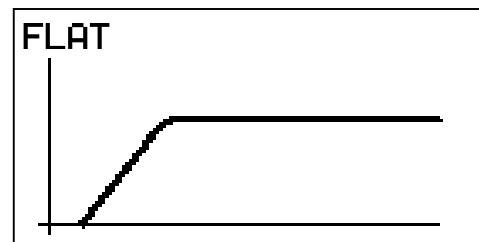

Fig. 21. Preset selection

4.4. AUDIO Menu

When the word AUDIO is displayed, press OK. The Gain screen will show up. At this point, use the MENU key to browse all the audio options: Gain, Parametric EQ, Limiter and Delay.

Press OK or slide your finger on the Circular key to start editing.

At this point, the Circular Key will be highlighted (blue ring in its center) to show that is active. To use the Circular Key, slide your finger over the white surface: clockwise to increment the value of the displayed parameter and counter-clockwise to reduce the value.



Circular key:

Slide finger clockwise to increment the value
Center blue ring is illuminated when they key is active
Counter clockwise to decrement the value



An asterisk (*) beneath the preset name means that the preset has been modified using the audio settings. When a new preset is loaded, all the changes made in the AUDIO Menu will be reverted.

4.4.1. Gain Menu

Inside the Gain menu, the Main, HF and LF input gains may be modified. Press OK to start editing the Main Gain (left bar). The cursor will blink to show that the value is being edited. Use the Circular key to modify the value.

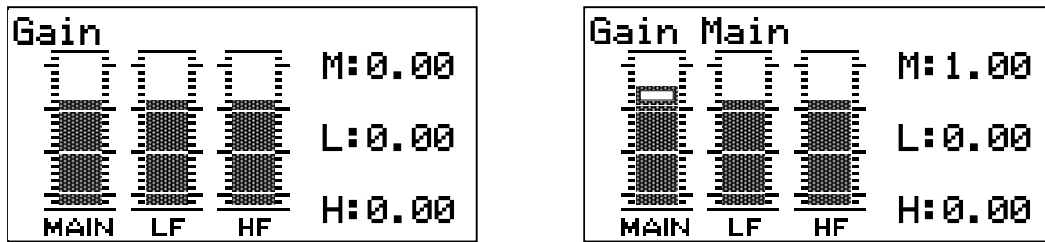

Fig. 22. Gain display (left) and Gain Main while editing (right)

At this point use the MENU key to change between the available gain settings: Main, LF and HF. Press OK to finish editing:

Gain Main: changes the overall gain of the system.

Gain LF: change the level of the Low Frequency way (woofer)

Gain HF: change the level of the High Frequency way (driver)

The gains can be adjusted between +3dB and -6dB. The current values are displayed on the right side of the display (in dB).



When changing the Main Gain settings, the actual sensitivity of the system is being changed too. When setting the value to +3dB, the input sensitivity will be reduced by 3dB (from nominal +8dBu to +5dBu).

4.4.2. 5-band EQ Menu

Inside the EQ menu, five parametric equalizers with fixed Q (Q=1) are available: Low (L), Low-Mid (LM), Mid (M), Mid-High (MH) and High (H). The central frequency for each band is: 100Hz, 250Hz, 1kHz, 2.5kHz and 10kHz, respectively.

It is possible to modify the gain of each band between +3dB and -6dB. The current edited value is displayed in the top right side of the display.

Press OK to start editing the EQ Low (left bar). The cursor will blink to show that the value is being edited. Use the Circular key to modify the value.

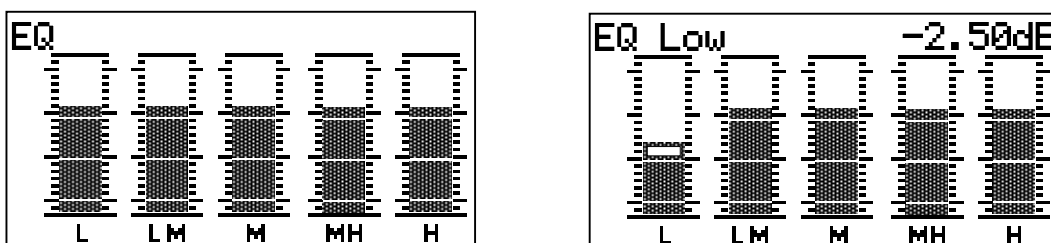

Fig. 23. EQ display (left) and EQ Low while editing (right)

At this point use the MENU key to change between the available EQ. Press OK to finish editing.

4.4.3. Limiter Menu

In the Limiter Menu, it is possible to modify the Threshold setting of the internal DSP peak limiter. Press OK to start editing the THRESH value (left bar). The cursor will blink to show that the value is being edited. Use the Circular key to modify the value, and press OK to finish editing.

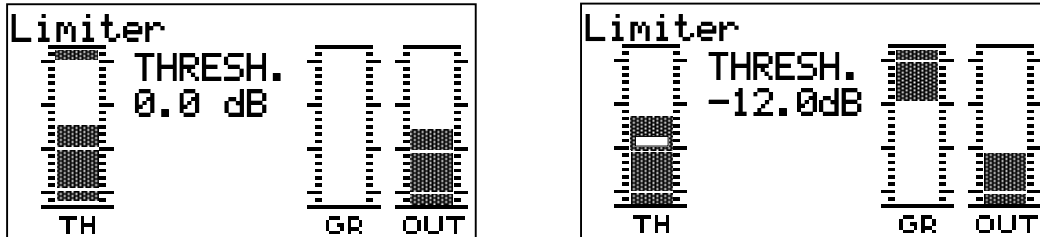

Fig. 24. Limiter display (left) and Limiter Threshold while editing (right)

The level bars TH, GR and OUT provide additional information when an input signal is connected to the device.

- TH (Threshold): Shows the actual value of the limiter threshold (cursor). Additionally, the bar will display the input level. The level of the threshold in dB is also displayed next to the bar in figures.
- GR (Gain Reduction): This bar shows when the limiter is active (the threshold value is being exceeded by the input level). The gain reduction level will display as an inverted VU bar (see Fig. 24, right).
- OUT: output level after the limiter. This is the actual signal level after the signal goes through the limiter. If the threshold is not reached, it will be the same as the input level. If the threshold is exceeded, there will be a reduction.



The limiter acts over the Peak limiter value. The system has also an internal RMS limiter that is fixed (see Section 4.7.1).

4.4.4. Delay Menu

In the Delay Menu, it is possible to add a Delay to the signal in the internal DSP. Press OK to start editing the Delay value. The cursor will blink to show that the value is being edited. Use the Circular key to modify the value, and press OK to finish editing.

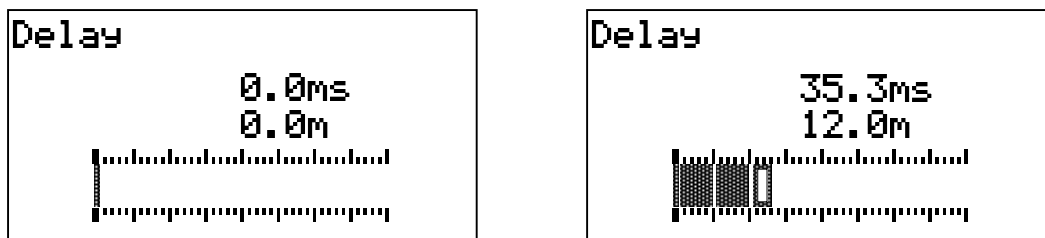

Fig. 25. Delay display (left) and Delay while editing (right)

The value of the Delay is displayed in milliseconds (ms) and meters (m). The value of the delay ranges from 0 to 40 meters (0 to 117.6ms).



The delay value is applied short after a value has been selected with the Circular key. When the delay is applied a short fade in / fade out of the output signal will be performed.

The centre led of the circular key will light off while this process is performed, and will light on again when the new value has been loaded.

4.5. SETUP Menu

When the word SETUP is displayed, press OK. The ECO Mode on/off selection will show up as in Fig. 26.

Here, use the MENU key to browse all the setup options: ECO Mode, Front Led, Front Limiter Indication, Mute, Loudness (ALC), LCD Backlight and Keypad Lock.

Press OK to change the value for the displayed selection (switch between ON/OFF).

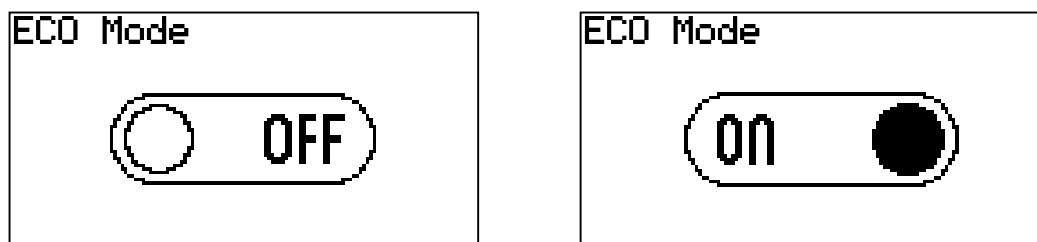

Fig. 26. ECO Mode option inactive (left) and active (right).

The options available under the SETUP Menu are summarised in the following table. For further information on each option, please read the following sections in this chapter.

	OFF	ON
ECO Mode	System will never go in low power mode	System will go in low power mode after 1 minute without input signal
Front LED	Front NITID Logo always OFF	Front NITID Logo always ON
Front Lim. Indication	Limiter status is not indicated on the front Logo	Front LED ON: Logo lights OFF when limiting Front LED OFF: Logo lights ON when limiting
Mute	Normal operation	Amplifier is MUTED
LCD Backlight	Backlight dims after 30 seconds	Backlight is always ON
Keypad Lock	Keypad will never lock	Keypad will lock after 30 seconds of inactivity

4.5.1. ECO Mode

When the ECO Mode is ON, the system will continuously analyse the input signal. When no input signal is present after 1 minute, the system will go in a low power consumption mode (standby). This condition will be indicated by a message in the LCD. When the audio signal is present again, the system will wake up and continue playing.

When the ECO Mode is active, the word Eco will be displayed in the main screen.



The system needs about 2 seconds to wake up from the low power consumption mode. It is not recommended to use it for time-critical applications.

4.5.2. Front LED

NITID active systems have a LED-backlight logo on their front grill. By default, the logo will light up when the cabinet is powered on. Select OFF to switch it off permanently.

4.5.3. Front Limiter Indication

When this feature is set to ON, the front backlight logo will also show when the amplifier is limiting, depending on the setting of the front LED:

- If the front Led is set to ON, the limiter active condition turns off the logo backlight.
- If the front Led is set to OFF, the limiter active condition turns on the logo backlight.

4.5.4. Mute

Select ON to Mute the amplifier. The MUTE condition will be shown in the main screen.

4.5.5. LCD Backlight

Select how the backlight of the LCD in the back panel will behave. When set to ON, the backlight is always active. When set to OFF, works in automatic mode: the backlight lights up after a key press, and light off after 30 seconds of the last key press.

4.5.6. Keypad Lock

When set to ON, the Keypad automatically locks after 60 seconds of inactivity. When set to OFF, Keypad remains always active.

Remember that to unlock the Keypad, the keys MENU and OK must be pressed simultaneously.

4.6. INFO Menu

This option provides a quick overview of all the current settings of the system. Press MENU to browse the different information pages, or OK to leave.

```
Audio Settings 1
Preset      : FLAT
Gain        : 0.00dB
Gain LF     : 0.00dB
Gain HF     : 0.00dB
Delay       : 0.0m
Limiter     : 0.00dB
```

```
Audio Settings 2
Mute: OFF
EQ LOW     : 0.00dB
EQ M-LOW   : 0.00dB
EQ MID     : 0.00dB
EQ M-HI    : 0.00dB
EQ HIGH    : 0.00dB
```

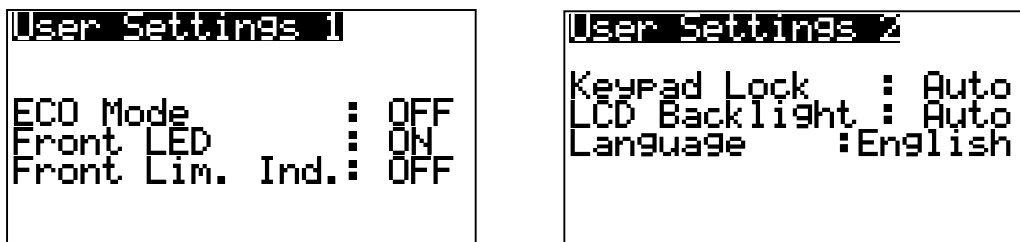

Fig. 27. Information screen for AUDIO and SETUP settings

After the information screens, the Language selection Menu will appear. Press OK if you want to change the language of the interface, or MENU to leave.

If you press OK, the menu will be active. Use MENU to select the desired option and OK to confirm.

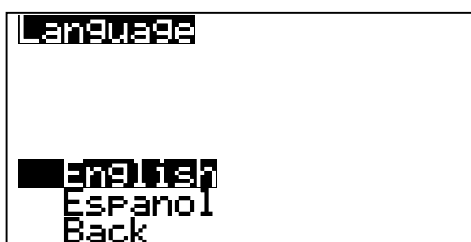

Fig. 28. Language setting Menu

Further languages will be available in future firmware releases.

On the last screen (System), it is also possible to reset the system to the factory values by clicking OK. In the Factory Setting Menu, press MENU to highlight the option Restore. Then press OK to confirm.

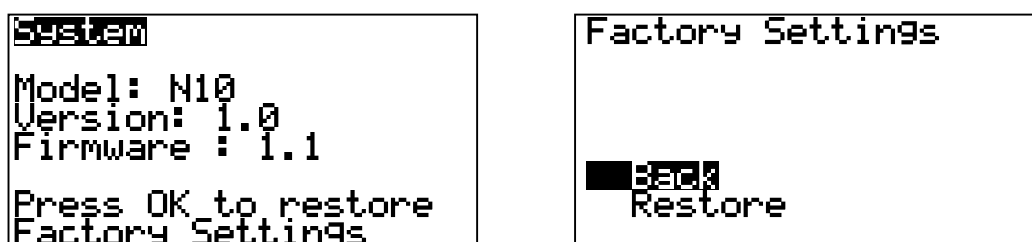

Fig. 29. System information (left) and Factory Settings Restore Menu (right)

4.7. Special DSP Features

4.7.1. RMS Limiter

NÍTID systems combine a carefully designed dual limiter system to independently protect each transducer against power overload: a peak Limiter and a RMS Limiter.

The RMS Limiter prevents long term exposition of the transducer to high RMS levels (abnormal when the music has a correct dynamic headroom). When the limiter led lights up continuously, it means that the RMS limiter is active. On the other hand, the Peak Limiter has an ultrafast attack to control the highest peaks of the music and only makes the Led blink.

Thanks to the large experience of Amate Audio on DSP algorithms and limiters, these limiters are highly effective but yet unnoticeable for the listener.

4.7.2. Automatic Temperature Limiter

Under normal operation, NÍTID amplifiers are able to perform during many hours at full power. However, should the temperature in the amplifier rise abnormally, the system will automatically adjust the limiter threshold to try to compensate for the temperature raise. The system will progressively lower the output gain.

When the temperature lowers again, the system will recover its normal operation. Should the temperature continue rising and reach 90°C at the amplifier's heatsink, the system will shut down in Protection mode.

4.7.3. Input Dynamic Compressor

NÍTID systems have a nominal input voltage of +8dBu / 2V (+2dBu / 1V in subwoofers) for full power performance; nevertheless, in order to respect the highest dynamics of the music, the input is capable to hold a high input voltage (+20dBu / 8V). This avoids undesirable effects from sound sources and mixers capable of delivering a higher output voltage.

It must be noticed that **driving a system continuously over its nominal input level may drastically decrease the sound quality**, normally because of the lack of headroom (dynamic response). In the long term, it might also produce unnecessary damaging of the transducers and reduce their reliability. The **maximum power of the system** is obtained at its **nominal input level**. Under this condition, the limiter LED may blink occasionally. Working continuously above this level is never translated into better results.

To avoid loudspeaker damage because of input overload issues, NÍTID systems build in an **input monitoring system that prevents the cabinet from being continuously operated at excessive input signal levels**.

After a period of exposure to high average input levels (over +2.5Vrms), a dynamic compressor will **progressively reduce the output power**, to protect the transducers.

The higher the voltage at the input is, the higher the reduction of the output power, being maximum reduction 18dB. While the dynamic compressor is active, the LIMITER ON LED and the Front LED will blink constantly.

To get back to the normal operation mode, the input level should be reduced to below 2 Vrms. After the level reduction, the system needs about 5 seconds to recover the normal operation mode.

4.7.4. Loudness (ALC)

The **ALC** feature is present when the Presets **FLAT** or **HPF90** are selected.

ALC is a DSP algorithm developed by the Research and Development team at **Amate Audio** to improve the listening experience when the cabinet is being used at low reproduction levels.

Under this listening condition, the behaviour of human ear is to naturally enhance the level of middle frequencies. The lower the level, the higher is the middle frequency enhancement. To compensate for that effect, **ALC** applies a correction to the frequency response of the system.

In order to do that, **ALC** automatically senses the average signal level at the input: when this level is low, the DSP will apply loudness compensation curves (based on Fletcher-Munson's equal loudness contours), that will dynamically adapt the frequency response of the cabinet to the listening conditions.

This feature will only influence the frequency response when the input signal average is below 6dB of the nominal input, that is, when the cabinet is performing at levels below half of its rated program power. In the range between -6dB and 0dB in respect to the nominal input, the **ALC** will not modify the response.

5. TECHNICAL FEATURES

N12A6	
Audio Input	
Sensitivity	+8 dBu – 1.94 V
Maximum Input Level	+20 dBu – 8 V
Impedance	20 kΩ
Type	Electronically balanced
Power Amplifier	
Program power	500 W (LF) + 100 W (HF)
Mains supply	Universal switching power supply 85-265VAC / 45- 65Hz
Avg. current draw (heavy duty musical program)	0.9A @ 230 VAC
Standby mode consumption	< 5 W
Connectors	2 x AC PowerCon (input, link) 2 x XLR (input, link)
Digital Audio Parameters	
Analog converters	24 bit / 48 kHz
DSP architecture	48 bit
Built-in delay line	118 ms / 40 m
Audio Performance	
Frequency response (-10 dB usable bandwidth)	52 Hz – 19 kHz
SPL (1m)	126 dB continuous, 129 dB peak
Nominal directivity (-6dB)	50° to 100° (H) x 55° (V)
Components	
LF	12" woofer (2.5" voice coil)
HF	1 x 1.4" PETP diaphragm ferrite magnet driver
Cabinet	
Type	Bass-reflex
Height	623 mm
Width	360 mm
Depth	390 mm
Weight (net)	20 Kg
Material	Multilayer birch plywood
Finish	Hi-resistance black matt Polyurea coating 2 mm steel front grille with black acoustic mesh

Note: Specifications subjected to change without prior notice.

DECLARATION OF CONFORMITY

In accordance with EN 45014:1998

Manufacturer's Name: "AMATE AUDIO S.L."
Manufacturer's Address: C/ Perpinyà 25, Polígon Industrial Nord
08226 Terrassa, (Barcelona), SPAIN
Brand: "AMATE AUDIO"

We declare under our own responsibility that:

Product: Active speaker systems with DSP. Audio apparatus for professional use
Name: Nitid N12A6

Conforms to the following product specifications:

Safety: IEC 60065-01 + A1
EMC: EN 55022:2006
EN 55103-1:2009
EN 55103-2 2009
FCC Part 15

WARNING:

In accordance to EN55022, this is a class A product. In a domestic environment this product may cause radio interference in which case the user may be required to take adequate measures.

Supplementary Information

The product herewith complies with the requirements of the:

Low Voltage Directive 2006/95/EC
EMC Directive 2004/108/EC
RoHS Directive 2002/95/EC
WEEE Directive 2002/96/EC

With regard to Directive 2005/32/EC and EC Regulation 1275/2008 of 17 December 2008, this product is designed, produced, and classified as Professional Audio Equipment and thus is exempt from this Directive.

Date of issue: July 1st, 2022

Signature:

AMATE AUDIO S.L.
N.I.F: B5903481
Violinista Velhoia, 18
Tel: +34 93731125
08222 - Terrassa
Barcelona - SPAIN



Joan A. Amate Martinez
General Manager



Conformity Marking



*Great sound
from Barcelona
since 1972*

The **NÍTID** powered loudspeaker systems have been
designed, engineered and manufactured in
Barcelona – SPAIN by

Amate Audio S.L.

Perpinyà, 25 · Polígon Industrial Nord · 08226 Terrassa
T. +34 93 735 65 65 – F. +34 93 735 60 48 –
info@amateaudio.com

R&D and FACTORY:
Violinista Vellsolà, 18 · 08222 Terrassa
T. +34 93 736 23 90 – F. +34 93 786 47 00

Barcelona – SPAIN

www.amateaudio.com